

# 18425-15

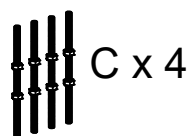

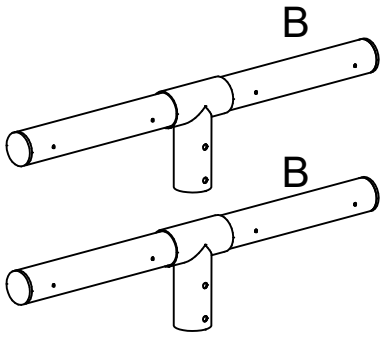

**x 2**

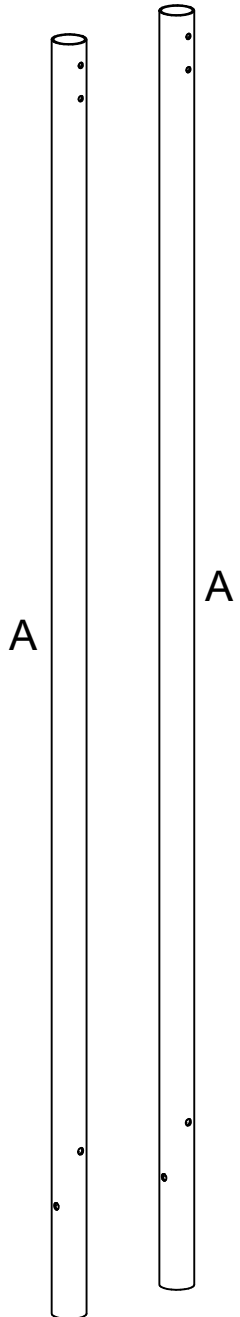
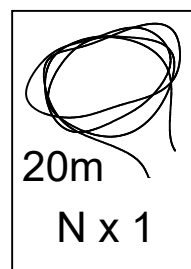
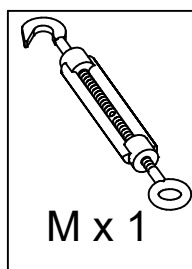
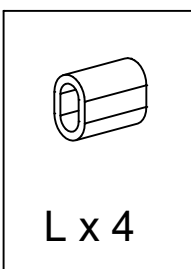
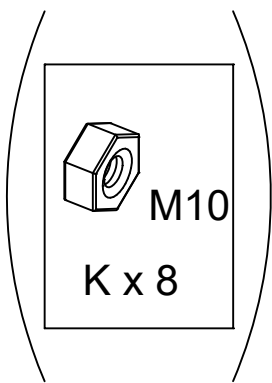
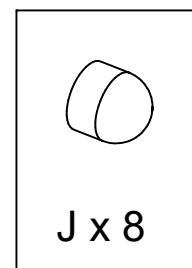
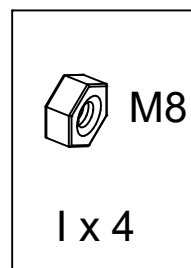
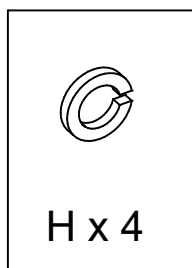
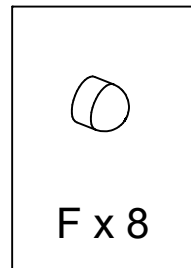
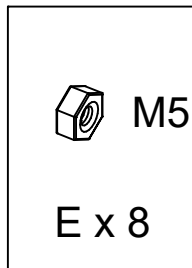
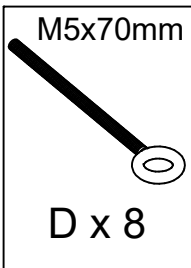
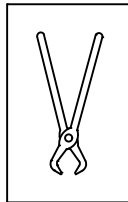
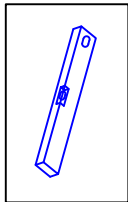
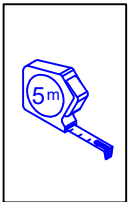
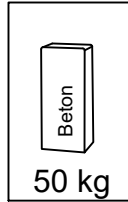
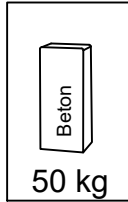
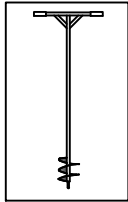
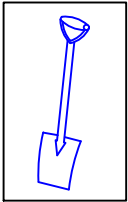
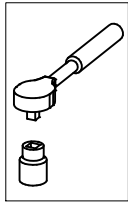
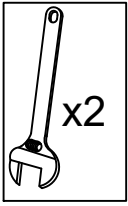
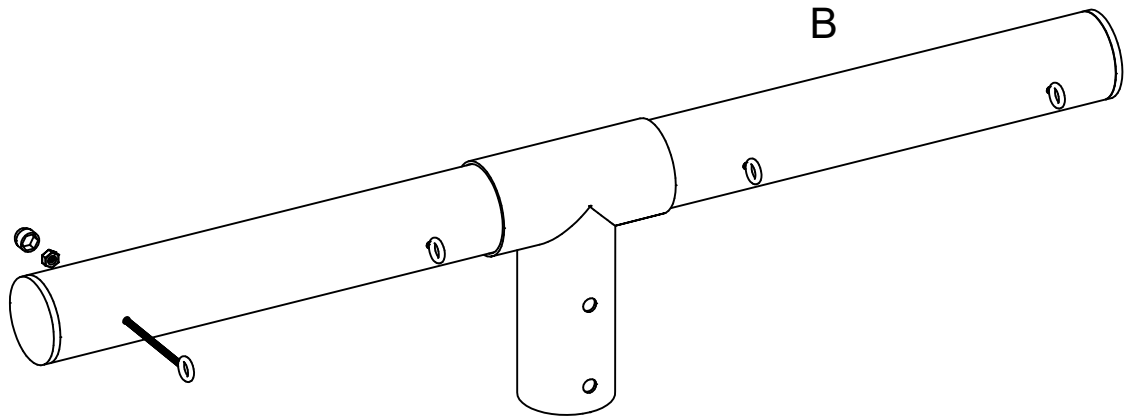
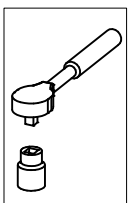
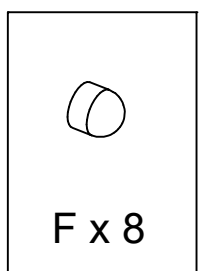
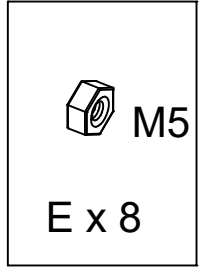
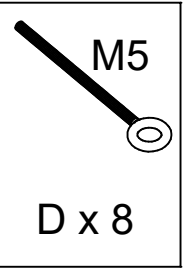
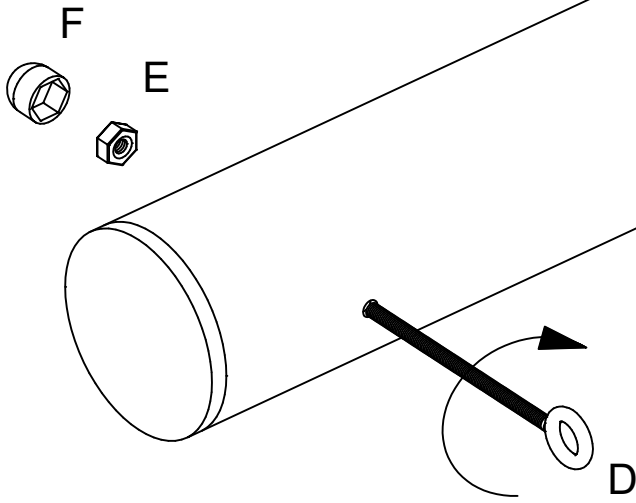
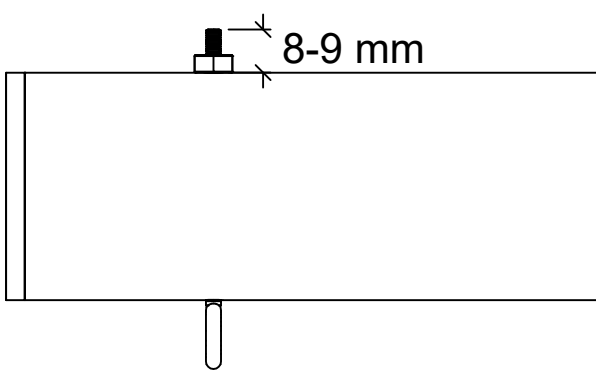

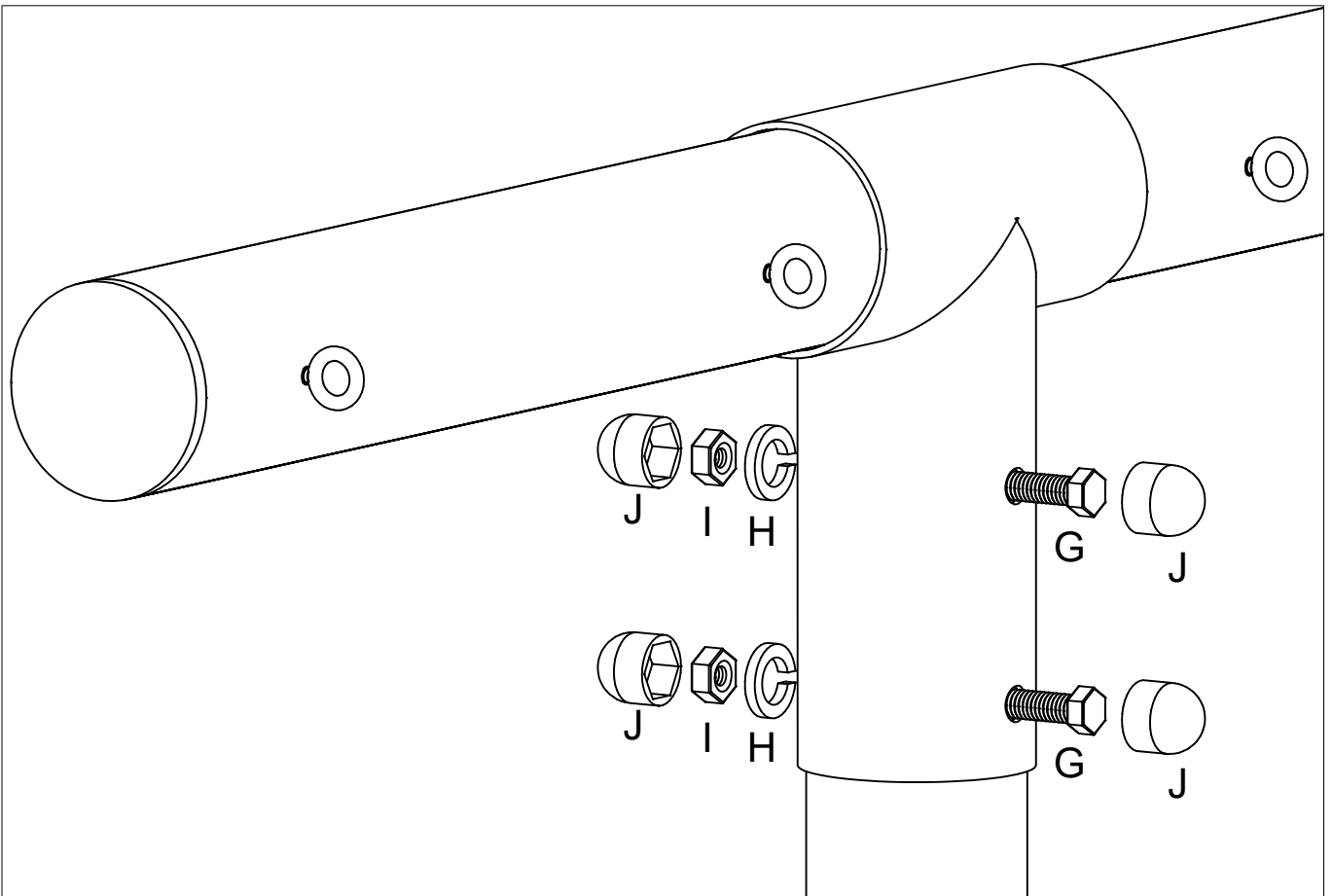
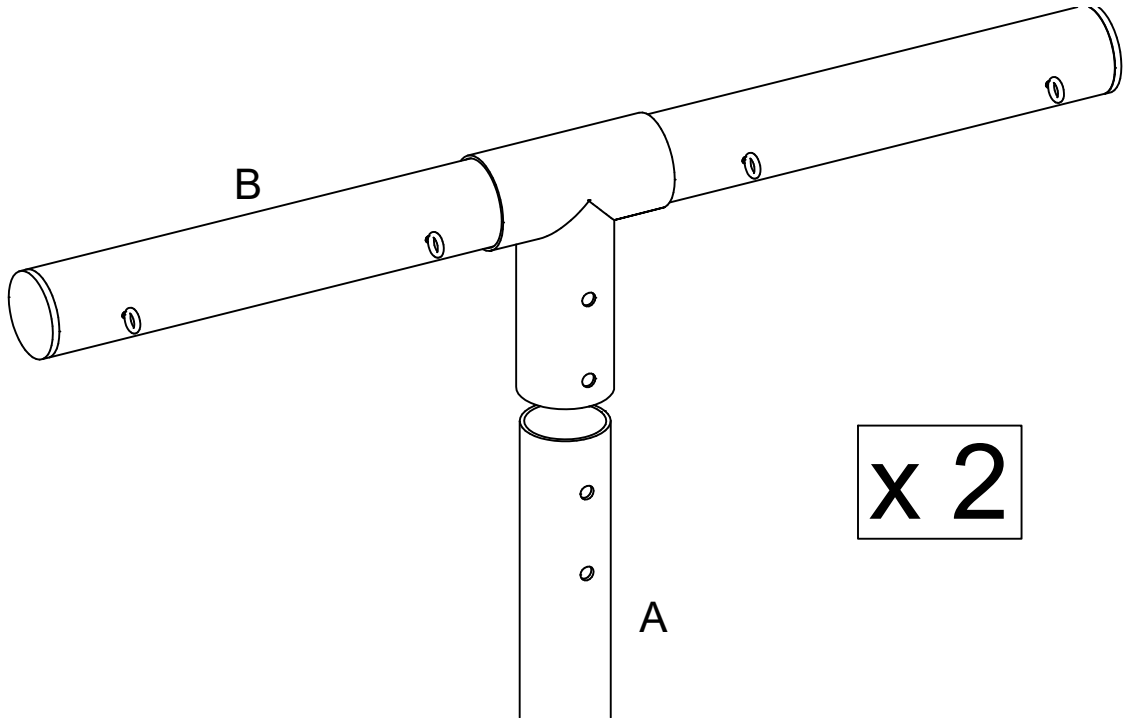
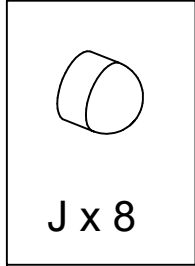
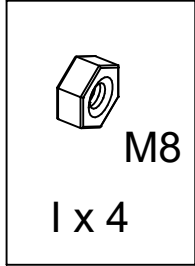
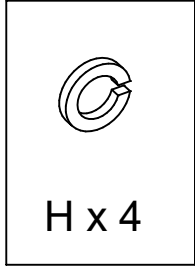
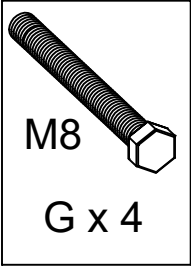

M10



K x 8

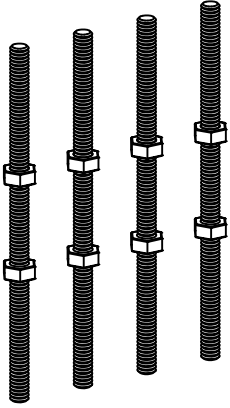

C x 4

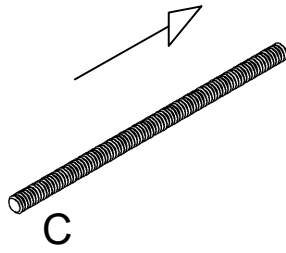
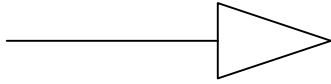

C

A

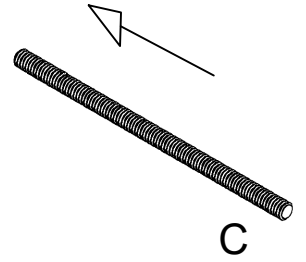
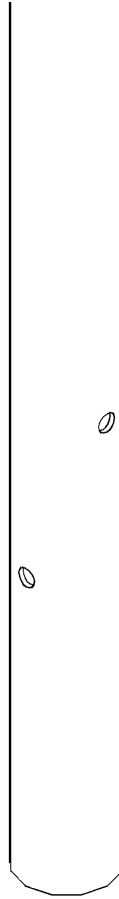

C

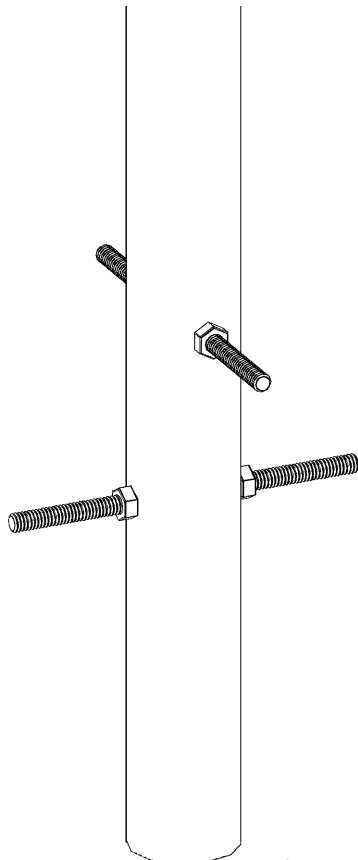

x 2

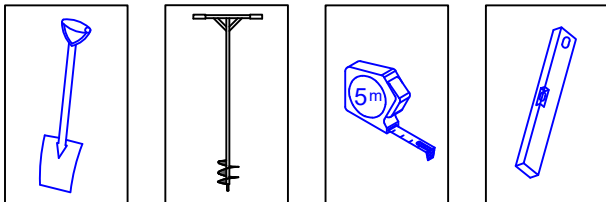
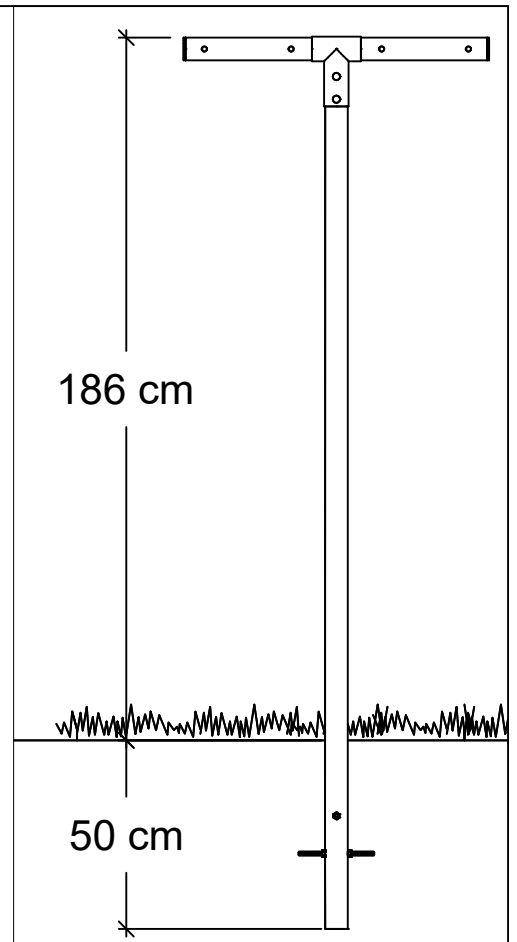
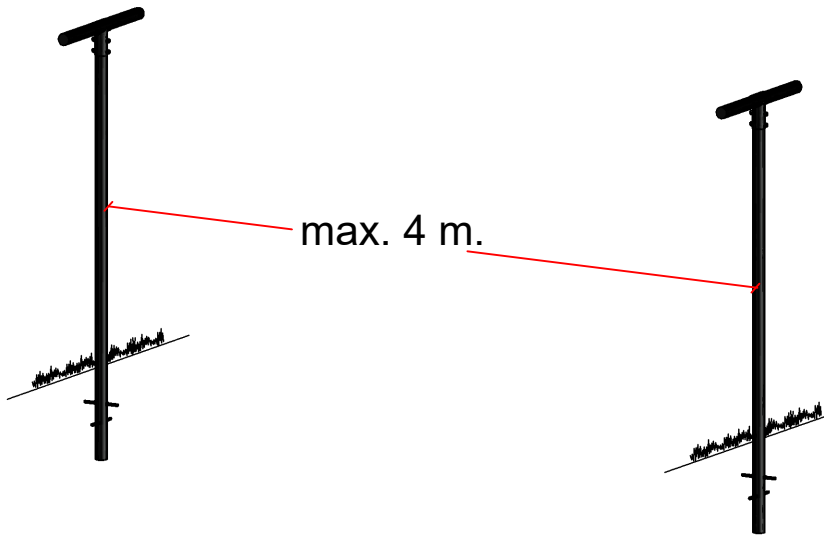

Der skal bruges 50 kg beton pr. stolpe.

Betonen skal hærde min. 1 uge før tørrestativet må tages i brug.

Pro Pfosten 50 kg Beton verwenden.

Der Beton muß mindestens 1 Woche härten, bevor das Trockengestell verwendet werden.

It takes 50 kg of concrete per post.

The concrete must harden min. 1 week before the drying rack may be used.

Det tar 50 kg betong per posta.

Betongen måste härda min. 1 vecka innan torkstället får användas.

50 kg de béton doivent être utilisés par Publier.

Le béton doit durcir min. 1 semaine avant l'utilisation de la grille de séchage.

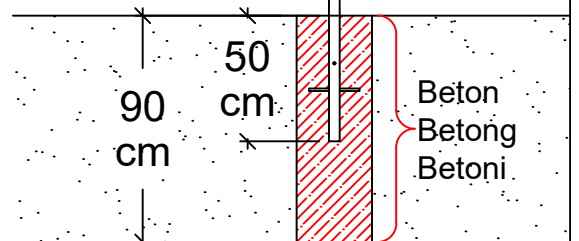
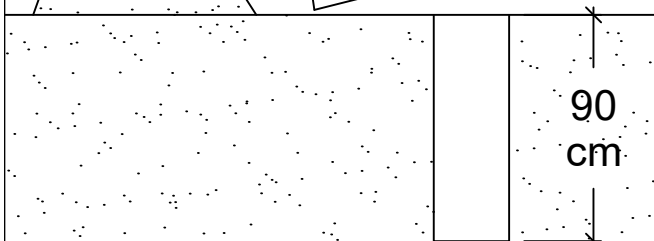
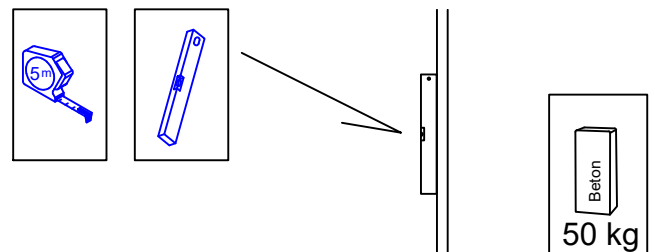
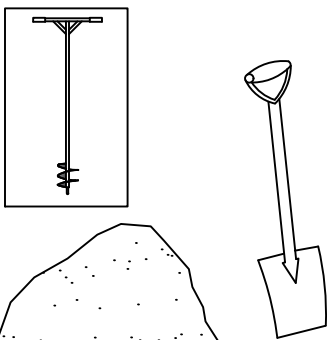

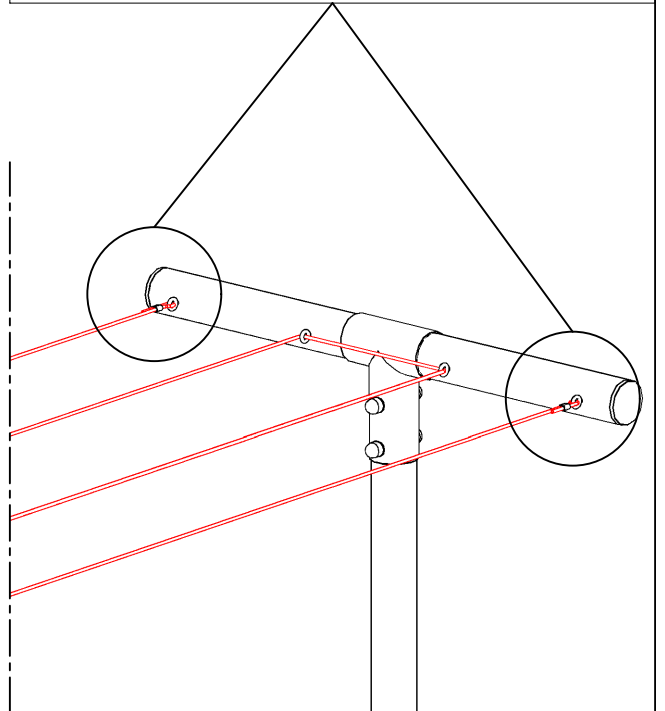
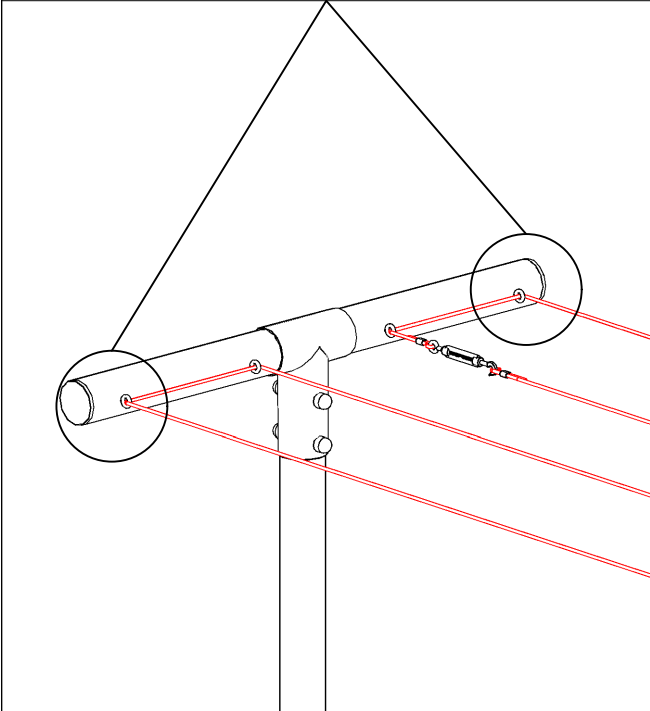
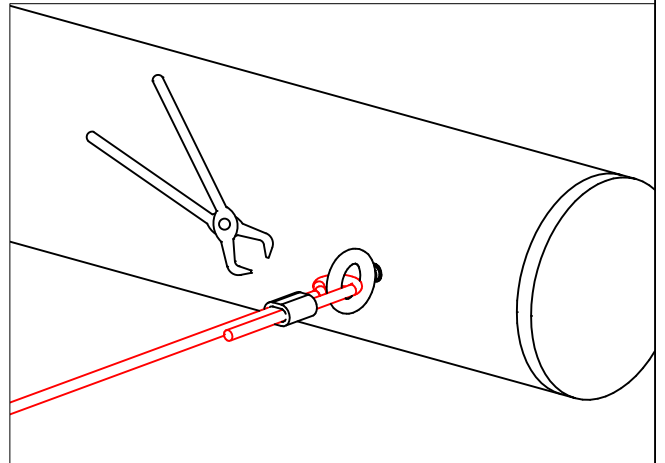
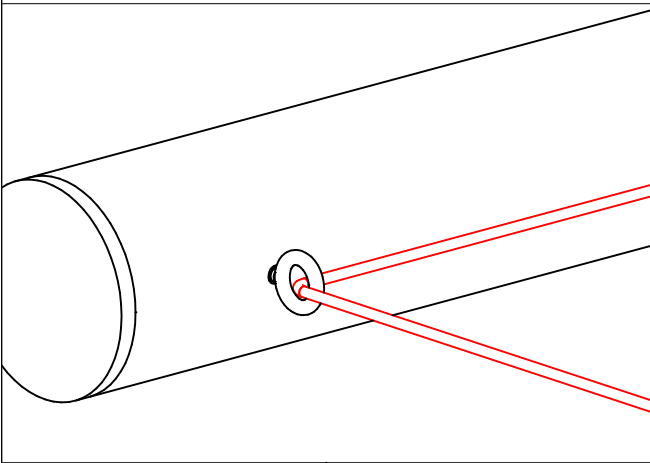
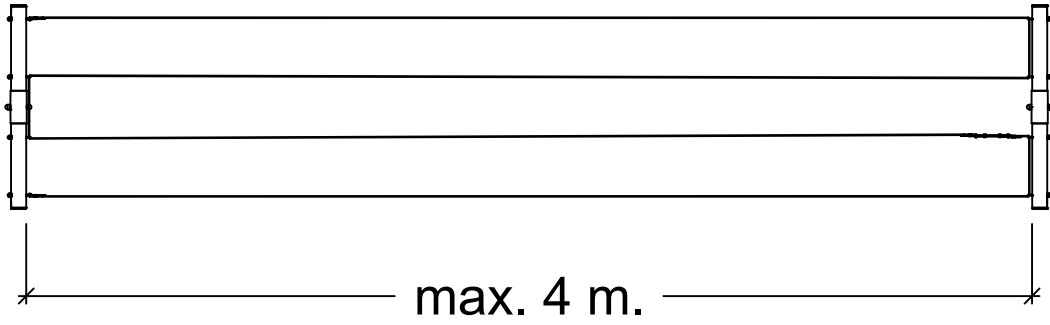
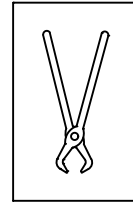
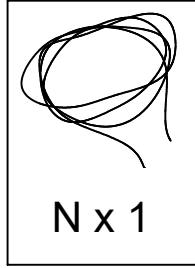
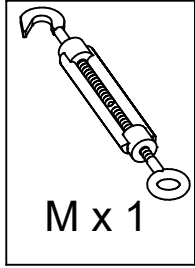
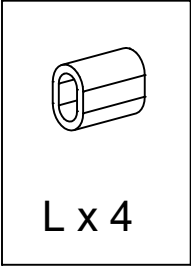

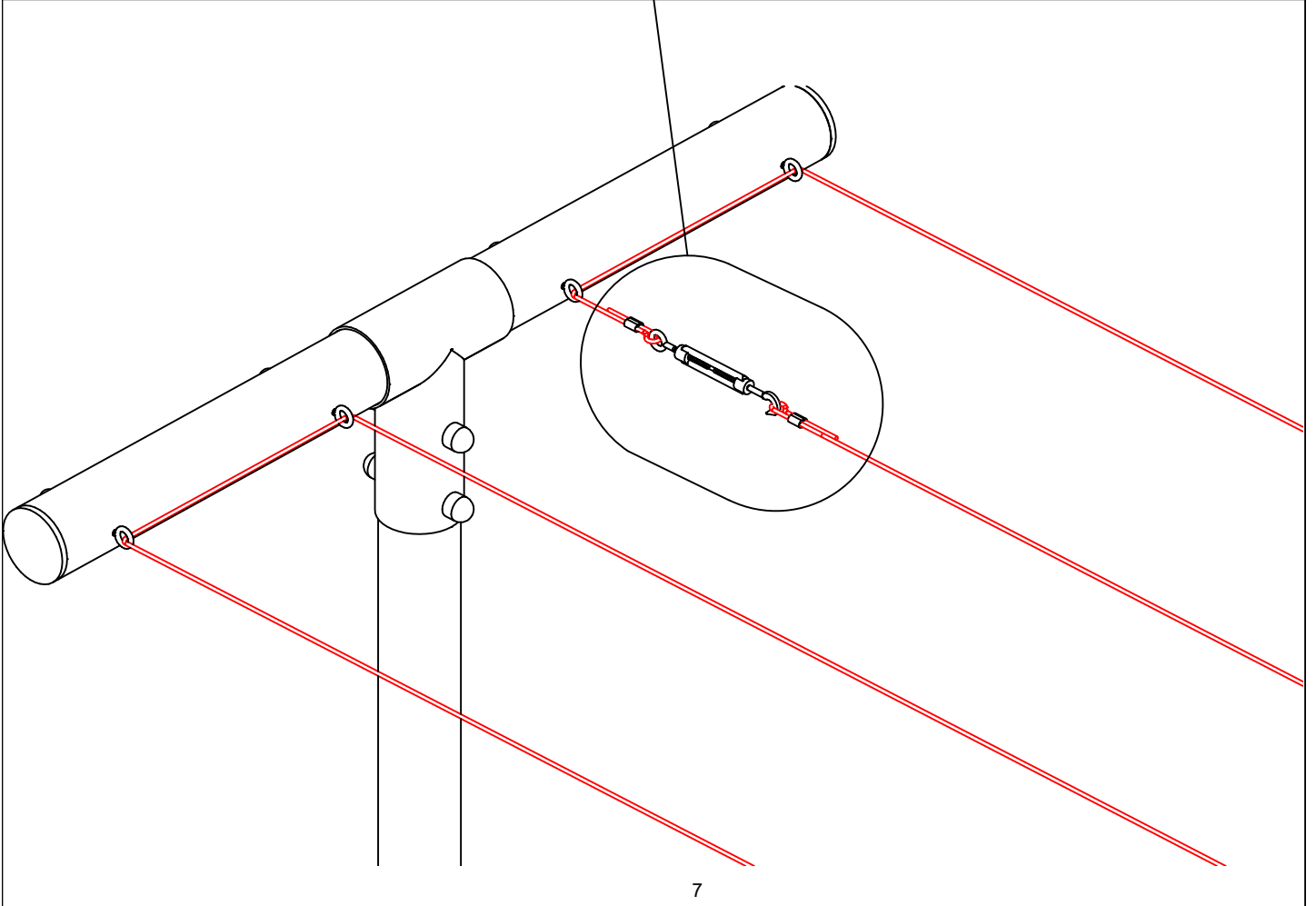
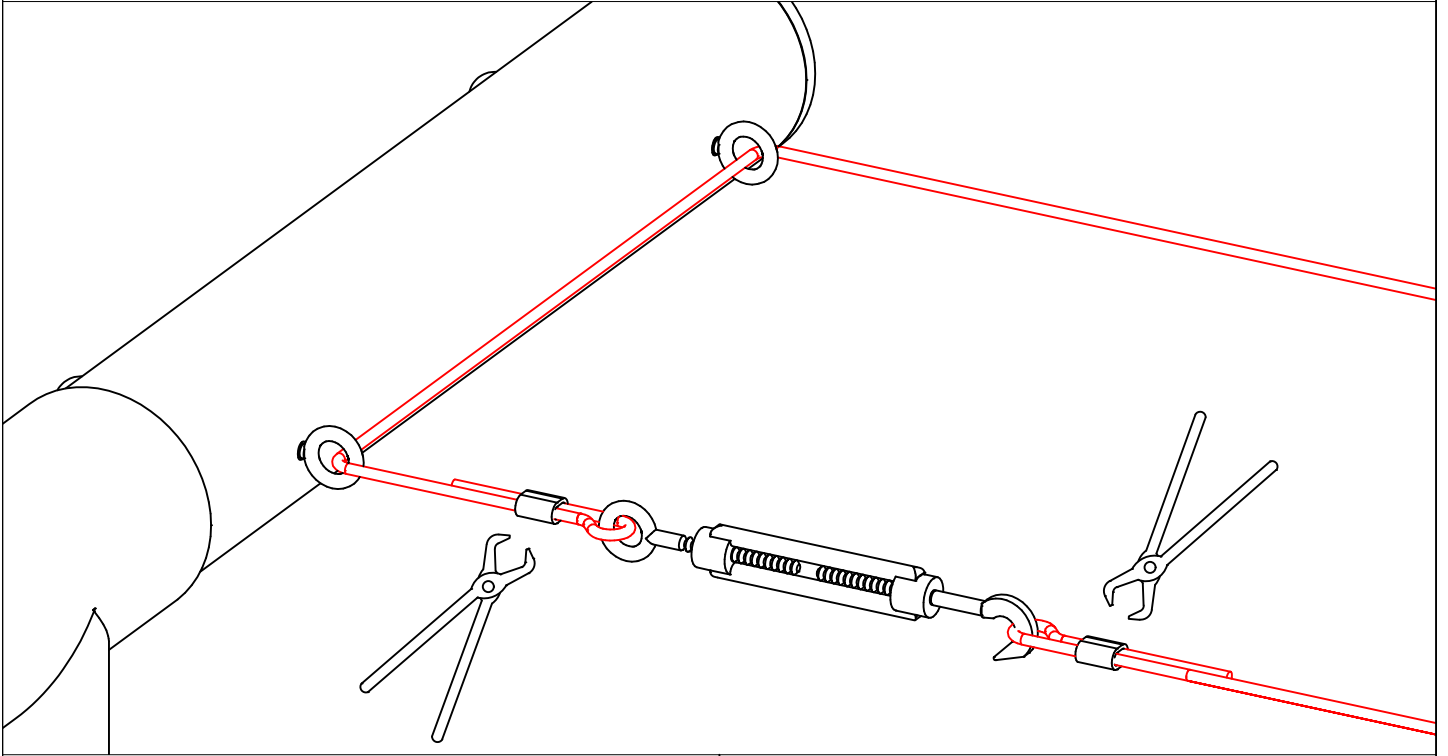
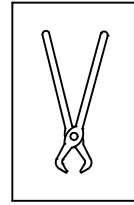
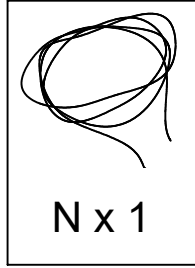
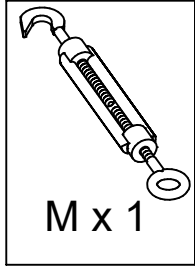
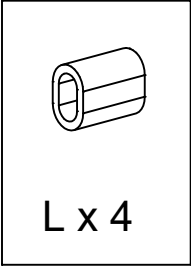

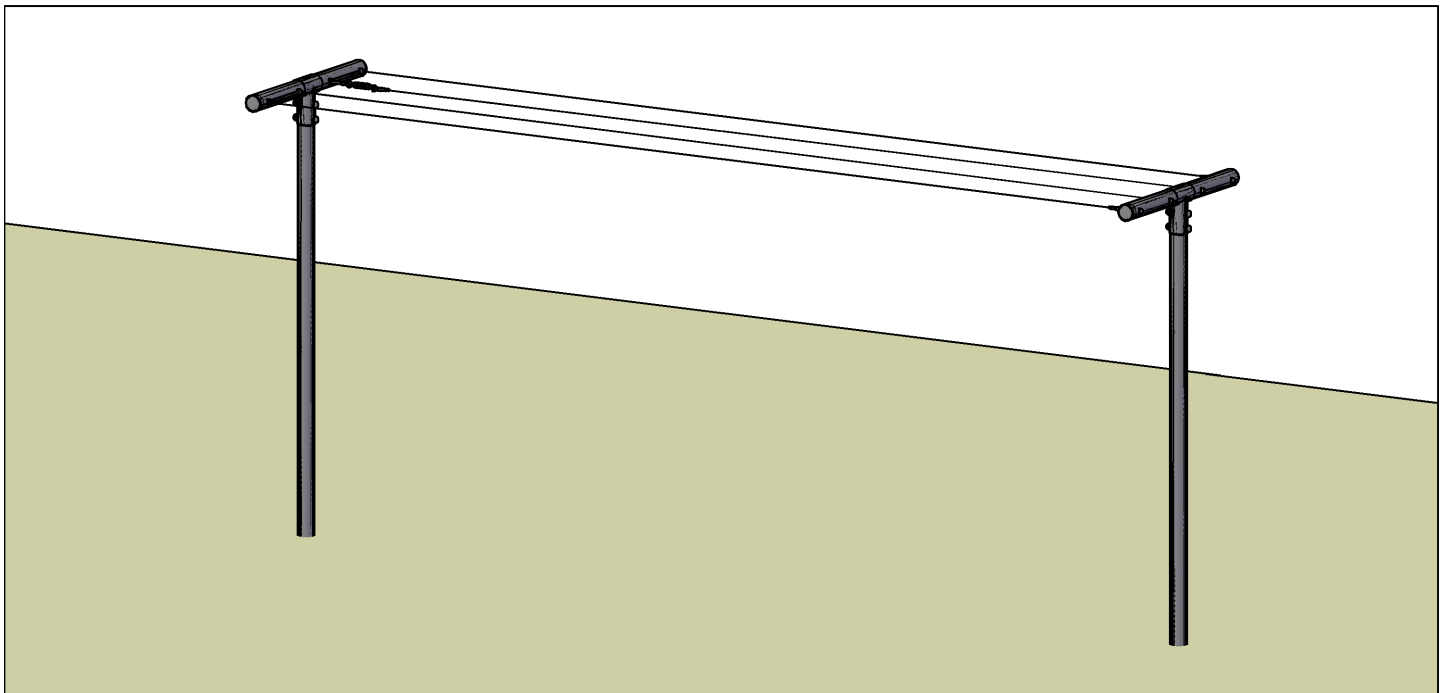

## PULVERLAKEREDE DELE

Ståldelene er varmgalvaniserede før pulverlakeringen, hvilket beskytter ståldelene mod rust. Den efterfølgende behandling med pulverlakering giver delene et stilrent udtryk. Der kan forekomme forskelligartede ruheder i overfladen, som stammer fra varmgalvaniseringen under pulverlakeringen. Delene kan rengøres efter behov med en klud og almindelig sæbevand.

## PULVERLACKIERTE TEILE

Die Stahlteile werden vor der Pulverbeschichtung feuerverzinkt, wodurch die Stahlteile vor Rost geschützt sind. Die anschließende Pulverbeschichtung verleiht den Teilen einen stilvollen Ausdruck. Es kann zu unterschiedlichen Rauheiten in der Oberfläche kommen, die von der Feuerverzinkung unter der Pulverisierung stammen. Die Teile können nach Bedarf mit einem Tuch und gewöhnlichem Seifenwasser gereinigt werden.

## POWDER COATED PARTS

Steel parts are hot-dip galvanised before powder coating, which protects the steel parts from rust. The subsequent powder coating gives the parts a stylish look. There may be roughnesses in the surface from the hot-dip galvanisation underneath the powder coating. The parts can be cleaned as needed with a cloth and ordinary soapy water.

## PULVERLACKERADE DELAR

Ståldelarna har varmförzinkats före pulverlackeringen, vilket skyddar ståldelarna mot rost. Den efterföljande behandlingen med pulverlackering ger delarna ett stilrent uttryck. Det kan förekomma ojämnheter i ytan som kommer från varmgalvaniseringen under pulverlackeringen. Delarna kan rengöras efter behov med en trasa och vanligt såpvatten.

## PIÈCES LAQUÉES EN POWDRE

Les pièces en acier sont galvanisées à chaud avant d'être laquées en poudre, ce qui les protège contre la rouille. Le traitement consécutif par laquage en poudre donne aux pièces un aspect élégant. Lorsque le laquage en poudre a lieu en même temps que la galvanisation à chaud, cela peut entraîner diverses rugosités dans la surface. Si nécessaire, les pièces peuvent être nettoyées avec un chiffon et de l'eau savonneuse.